



## Backyard Composting of Yard Waste<sup>1</sup>

Roger A. Nordstedt, Anne W. Barkdoll and M. Elizabeth Will<sup>2</sup>

### WHAT IS COMPOSTING?

Composting is a biological decomposition of organic wastes by bacteria, fungi, worms, and other organisms occurring under controlled aerobic conditions. The organisms use carbon, nitrogen, and other nutrients released from the organic matter during the decomposition process. The result is an accumulation of dark, friable, partially decomposed material. In the home yard, the process can be managed by placing the raw organic materials in a backyard composting structure. Raw materials for composting include leaves, pine needles, twigs, grass, and vegetable wastes from the garden and kitchen. Proper management is a key factor, since an unmanaged compost heap may become an eyesore and an odor nuisance.

### WHY COMPOST?

Composting of yard trash is an environmentally sound way of reducing solid waste by recycling a useful resource where it is generated. Yard trash material makes up about 20% of the volume of collected municipal solid waste, and seasonally it may account for up to 80%. Keeping this material out of the waste stream will extend the useful life of existing landfills and slow the need to acquire more land for future landfills. Composting also creates a useful soil amendment. Most people compost for personal reasons, such as the need for organic material in the garden, and/or as a way of fulfilling their commitment

to recycling. Whatever the motivation, an understanding of the requirements for successful composting is necessary.

### WHAT CAN BE COMPOSTED?

Many types of organic materials are readily composted. Yard trash such as fallen leaves, remains of garden plants, non-woody plant trimmings, and grass clippings can be composted, as well as vegetable kitchen scraps. Some "raw" (uncomposted) organic materials, such as grass, weeds, and green garden plant waste, contain fairly large amounts of nitrogen. Others, such as leaves and small twigs, contain much less nitrogen and a higher proportion of carbon. Materials with higher nitrogen levels may decompose so rapidly that some of the nitrogen and other nutrients are lost before they can be used by growing plants. Excess nitrogen levels may also cause nitrogen to be lost as ammonia thus causing odor problems. Materials containing low levels of nitrogen and high levels of carbon may cause nitrogen deficiencies in the plants if they are added directly to the soil. This is caused by the microorganisms which use nitrogen as they degrade organic material thus competing with the plants for nitrogen. If nitrogen is present in insufficient quantities plant nitrogen deficiencies may result. To avoid this problem, raw materials with high nitrogen should be combined with those with low nitrogen. This will result in a better compost.

1. This document is Circular 958 (available only via CD-ROM), Florida Cooperative Extension Service, Institute of Food and Agricultural Sciences, University of Florida. Publication date: November 1991.
2. Roger A. Nordstedt, associate professor; Anne W. Barkdoll, post-doctoral associate; M. Elizabeth Will, former post-doctoral associate, Agricultural Department, Cooperative Extension Service, Institute of Food and Agricultural Sciences, University of Florida, Gainesville FL 32611.

The Institute of Food and Agricultural Sciences is an equal opportunity/affirmative action employer authorized to provide research, educational information and other services only to individuals and institutions that function without regard to race, color, sex, age, handicap, or national origin. For information on obtaining other extension publications, contact your county Cooperative Extension Service office.  
Florida Cooperative Extension Service / Institute of Food and Agricultural Sciences / University of Florida / Christine Taylor Stephens, Dean

With proper lawn management, grass clippings do not need to be removed from the lawn. If grass clippings are collected and composted, they should be mixed with other yard waste to provide bulk and a proper ratio of two important plant nutrients, carbon and nitrogen (C/N). Otherwise, the clippings may compact and restrict air flow in the compost pile and cause unpleasant odors.

Twigs, branches greater than 1/4 inch in diameter and fibrous palm fronds should be processed in a shredder/chipper before composting. Leaves, especially waxy types such as live oak, laurel oak, water oak, and magnolia, also benefit from being shredded before composting. Larger woody material can also be composted but requires a longer time to decompose. When chipped to a small size and supplemented with a nitrogen source, decomposition can be accelerated.

Most plant disease organisms and plant seeds are destroyed by high temperatures (130-140°F). These high temperatures may be reached in the pile during proper composting, however it is usually difficult in a home composting system to mix a pile well enough to bring all wastes to the center and assure complete destruction of seeds and pathogens. This being the case, it is not advisable to add large amounts of seed-laden weeds or diseased plants to the compost pile if the resulting compost is to be used in the garden. The high temperatures generated in compost also inhibit harboring and breeding of insects in the compost pile. Plants treated with pesticides should not be added to the compost pile.

Kitchen wastes, such as vegetable and fruit scraps, coffee grounds, and egg shells, may also be added to the compost pile, but they should be incorporated immediately to avoid odors. Although meat scraps, fat, bones, grease, and dairy products are compostable, they should not be incorporated in the home compost pile. These items attract animals, create nuisance odors, and are slow to decompose.

Sawdust may also be added to the compost pile in moderate amounts if a high nitrogen material is being composted or if additional nitrogen is applied. Approximately 1 pound of nitrogen (6 cups of ammonium nitrate) is required for every 100 pounds of dry sawdust. Wood ashes are a source of lime and should be added to a compost pile only in small amounts if at all. Large amounts of lime will cause loss of nitrogen from the pile.

Although ordinary black-and-white newspaper is compostable, it has a low nitrogen content and decomposes slowly. It tends to compact and restrict air flow unless shredded. It is recommended that newspaper be recycled rather than composted. Other organic materials that can be used to add nutrients, particularly nitrogen, to a compost pile include livestock manures.

## COMPOSTING PRINCIPLES

Rapid composting requires an environment in which microorganisms will thrive. Optimum moisture, aeration, temperature, particle size and carbon to nitrogen ratio are important for efficient composting.

### Moisture

Microbial activity requires adequate moisture, usually 40-60%. At this moisture level, a handful of the compost will feel wet but water cannot be squeezed out of it. The compost pile must be kept moist, but not soggy. Materials which are too wet will compact and restrict the movement of air through the pile. It may be necessary to add more water during the composting period if the weather is dry.

### Aeration

Microbes active in composting require oxygen to efficiently break down organic materials. Bulky materials such as leaves, pine needles, chipped twigs, and straw keep the compost pile from settling and allow air to enter. The compost pile should be periodically turned or mixed to incorporate oxygen. Heat is generated by the microbes during the decomposition process. Turning also shifts material from the outer (cooler) part of the pile to the center (hotter). The frequency of turning depends upon the materials being composted, the compost temperature and the moisture conditions, but generally should be done on a weekly basis in warm weather. Turning should definitely be done if the temperature in the center of the pile reaches 140°F or if odors are present.

### Temperature

Temperature is a function of pile size, oxygen and moisture content. To reach temperatures desirable in composting, a pile must be large enough to provide an insulating effect for the interior of the pile. Temperature is an important environmental factor affecting biological activity, and composting is

dependent on this activity. Each type of organism has an optimum temperature range. Composting is designed to function in the range of 95°F - 160°F. The most effective range for composting seems to be 122°F - 131°F. Higher temperatures of 131°F - 140°F may be desirable to destroy weed seeds or plant pathogens. At temperatures above 149°F many of the organisms involved in composting become inactive or die.

### Particle size

Reduction in the particle size of raw materials will increase the speed of the composting process by increasing the surface area available for microbes to attack. It is therefore a good idea to put small limbs and twigs through a chipper before composting. Leaves may be processed in a shredder or cut up with a lawn mower, preferably with a mulching attachment. This will break the waxy coating and expose the more easily degraded interior of leaves. Size reduction also reduces the volume of the compost pile, thereby saving space. Particle size could be too small if the pile were constructed of material the size of saw dust. This would decrease aeration, reduce the rate of composting and perhaps cause anaerobic conditions.

### Nitrogen level

Microbial activity is affected by the C/N ratio of organic material. Materials high in carbon relative to nitrogen (i.e.  $C/N > 30$ ), such as straw and sawdust, will decompose very slowly unless a source of nitrogen is added. Materials with a low C/N ratio are good sources of nitrogen and include manure, inorganic fertilizer, vegetable table scraps and grass clippings. The optimum C/N ratio for rapid composting is about 30/1 or less. The approximate C/N ratio for materials (Table 1) commonly used in backyard composts ranges from about 15 to 600.

## DESIGNING AND BUILDING A COMPOSTER

The type of composter which is used should be the one that best suits the needs and capabilities of the user. They vary greatly in expense and in the amount of physical labor required to manage them. Several types of units are described below that can be made at home, although units of similar design can also be purchased.

**Table 1.** Approximate C/N Ratio for various materials commonly used in backyard composts.

Material	C/N Ratio
Fruit Wastes	35
Grass Clippings	20
Leaves	60
Rotted Manures	20
Sawdust/Wood	600
Straw	100
Table Scraps	15

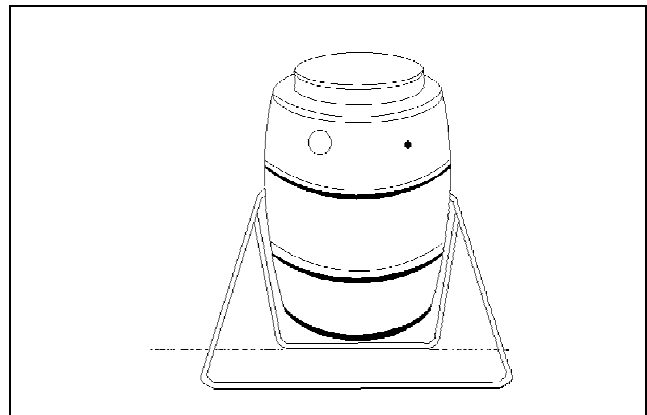

**Figure 1.** Drum Composter

### Drum composter

If you have a small amount of waste or want to make only a small amount of compost, composting can be done in a covered garbage can or other metal or plastic can (Figure 1). Holes ( $\frac{1}{2}$  inch in diameter) should be made in the sides and bottom of the drum and it should be set up on blocks to allow air circulation and water drainage. The material can be mixed and aerated with a garden tool or by turning the drum on its side and rolling it around on the ground if it has a secured lid. The drum can also be placed on rollers or casters to make turning easier. More elaborate drum composters can be fabricated by mounting the barrel on a pipe. The pipe can be placed through the sides or through the ends of the barrel. Reinforcing can be provided with a pipe floor flange. Pipe floor flanges are available at most hardware stores. The barrel can be suspended by supporting the pipes on posts, blocks, or other structure. A hinged door can also be placed on the barrel to facilitate loading and unloading of the drum composter. Turning of the composting material is also much easier with this type of drum composter.

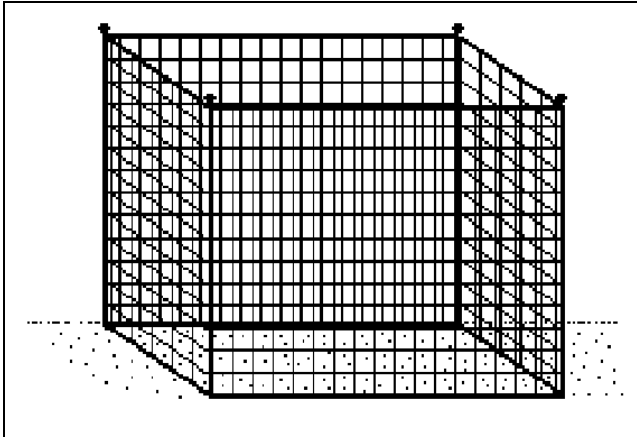

**Figure 2.** Woven or Welded Wire Bin

### Woven or welded wire bin

Another method is to build a pile within a pen of flexible woven wire or snow fencing (Figure 2). The structure may be 3 to 5 feet in diameter and 4 feet high. Advantages of this design are that air can circulate freely through the pile, and it is easy and inexpensive to relocate. To turn the pile, the wire cylinder is disconnected, removed from around the current pile, and set up again close by. The composting material can then be placed back in the newly located bin. This design can be made more stable and easier to manage by attaching the wire to wood or metal fence posts with a gate or removable panel on one side. The material would be turned with a pitchfork or a compost turner (described below).

### Three-chamber bin

A durable structure for rapid composting is the three-chamber bin (Figure 3). It holds a fairly large amount of compost and allows good air circulation. This design works as an assembly line with the compost in each bin being at a different stage in the decomposition process. The raw material is started in the first bin where it is allowed to heat up for 1 to 2 weeks. It is then moved into the next bin and left for another 1 to 2 weeks while a new batch is started in the first bin. Finally, the material in the middle bin is placed in the last bin to cure to a finished compost. This type of structure is not limited to three bins. Four or more bins may be constructed, always leaving at least one empty bin for fresh material.

Good construction materials for the three-chamber bin are wood that has been treated with a preservative to prevent rotting and vinyl-coated wire

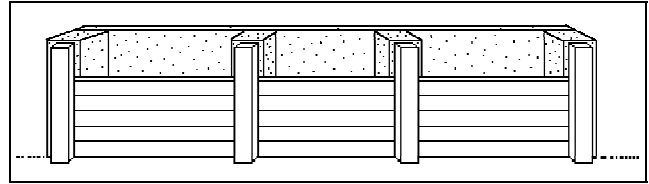

**Figure 3.** Three-Chamber Bin

mesh. Each bin should be about 3 feet by 5 feet and 3 or more feet high. The floor in the bins can be earthen, wood, or other porous material. Removable wood slats on the front of the bins can be held in place by posts. The slats will increase the capacity of the bins and make the loading and unloading of the bins much easier.

The three-chamber bin can also be made with concrete blocks or bricks laid together. Spaces may be left between the bricks or blocks to allow free air circulation into the compost material. The blocks can also be mortared or fastened together with surface bonding cement for a more permanent structure. However, provisions should be made for aeration holes if the blocks are mortared or bonded together.

## COMMERCIALLY AVAILABLE COMPOSTERS AND ACCESSORIES

Several types of compost units and a variety of useful accessories can be purchased from garden supply stores and mail-order catalogs. The composting units range in price from less than \$100 to a few hundred dollars. They offer an alternative to those who do not want to construct their own unit. Durability and ease of loading, unloading, and turning are important features to look for in a composter.

The commercial composters, designed to make the process as labor free and attractive as possible, are generally of two designs; drum tumblers (Figure 1) and bins (Figure 2 and Figure 3). The bins are constructed of either plastic or galvanized metal, sit directly on the ground, have hinged or removable lids, and are attractively made and animal-resistant. Loading and turning instructions are usually provided with the composter. The drum style composters are metal or molded plastic barrels mounted on a stand, either vertically or horizontally. The material is loaded and unloaded through a door on the side or on one end. The compost is turned by rotating or tumbling the drum. Desirable features include quality of construction, height and size of the loading door, and ease of turning. The loading door should be high enough to accommodate a wheelbarrow but not so

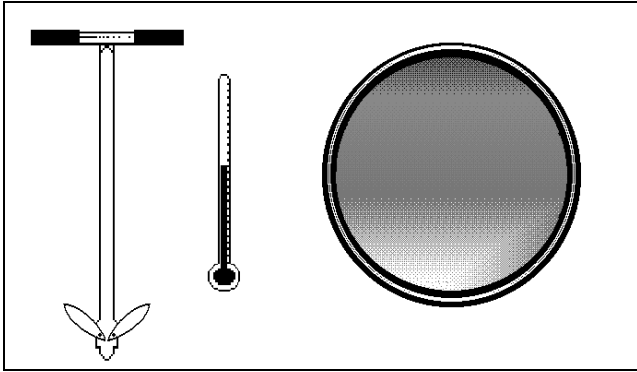

**Figure 4.** Compost Accessories: compost turner, thermometer, screen.

high as to necessitate lifting the material above the waist during loading and unloading. The vertical drum units tend to be a little more awkward to turn when the drum is full.

Available accessories can make composting more efficient and easier. As noted earlier, if the particle size of the raw material going into the composter is smaller, the composting process will take less time. Several shredders and chippers powered by an electric motor or gas engine are available. Choosing the proper equipment to do the job is important. Machines that are called "leaf-shredders" are often inexpensive and powered by electricity. The cutting of the leaves may be done with a rapidly rotating, replaceable nylon filament. They are not designed to shred large material. Chipper/shredders, on the other hand, come in several sizes depending upon the size of material to be processed and desired capacity. They are considerably more expensive than leaf shredders, ranging from a few hundred to several hundred dollars.

Other accessories include thermometers for measuring the internal temperature of the compost pile and screens for processing the finished compost (Figure 4). The screens can be used to remove materials to be recycled for further composting, or to size the compost for specific end uses. There is also a compost turner available that, when inserted into a compost pile and then withdrawn, pulls material from inside the pile to the outside (Figure 4). This action mixes and aerates the composting material. Various types of inoculum are also available for compost piles. The organisms necessary for composting are rarely a limiting factor as they are already present on the material to be composted. Research has not shown inoculum addition to be necessary for composting except perhaps in special cases. These accessories can

be purchased through mail order catalogs advertised in gardening magazines.

### GETTING STARTED - BUILDING THE COMPOST PILE

Choose a location for the compost pile which is near a water spigot. Consider how you will get the raw materials to the pile and how you will move the finished compost to areas in which it will be used. A partly sunny area protected from drying winds and with good drainage is best. The size of the pile may vary greatly with the amount of materials on hand. It should not be less than 3 feet high and 3 feet wide, or it may not maintain the high temperatures necessary for rapid decomposition. Drum composters should be filled to no more than about 2/3 of their capacity in order to assure proper mixing.

The compost pile should be built in layers or all ingredients should be thoroughly mixed. This helps ensure the proper mixing of nitrogen-rich and carbon-rich materials. There are a variety of "recipes" for adding materials to piles; however, some general rules apply. Successive layers, each 3 to 4 inches deep, of different types of materials should be used:

1. nitrogen-containing material such as manure, kitchen waste, grass clippings, or inorganic fertilizers containing nitrogen.
2. bulky material such as leaves, chipped twigs, straw, or sawdust.

Water should be applied between each completed set of layers to achieve the proper moisture content. The material should be wet, but not so wet that you can squeeze water out of it with your hand.

### MAINTAINING THE COMPOST PILE

The compost pile should be periodically mixed to incorporate oxygen (which is required for composting) and to expose seeds, insect larvae, and pathogens (disease-causing organisms) to the lethal temperatures at the core of the pile. This can be done with a pitchfork, shovel, or a tool that can be purchased which is specially made for this task. Check the internal temperature of the compost pile regularly and turn the pile when it reaches about 140°F. Piles should be turned immediately if ammonia or offensive odors associated with anaerobic conditions (lack of oxygen or air) are detected. Anaerobic conditions can be caused by too much water or by compaction.

Within a few weeks after starting, the pile should be hot in the center. Heating indicates that the material is composting properly. Temperatures within the compost pile increase during the decomposition process and may approach 150°F or higher. Failure to heat may be the result of too little or too much water, a lack of nitrogen, air not getting into the center of the pile (material packed too tightly), or the pile being too small. As the material decomposes, the pile may shrink to about one-half its original volume. The composting process is complete when there is no heat produced in the pile after turning and the material is dark, friable and does not contain distinguishable plant parts like leaves.

The compost is ready to use after 1 to 12 months, depending on the degree of initial shredding and level of management. The material will be dark and crumbly in texture, fairly dry, and have an earthy odor. Depending on the intended use of the compost, it may be desirable to put the material through a 1/2 inch screen before using. The larger particles can be returned to the compost pile to decompose further.

## USING COMPOST AROUND THE HOME

### Soil Amendment

A layer of compost 1 to 3 inches thick may be worked into garden soil. When incorporated in this way, compost adds small amounts of nutrients to the soil and serves to:

1. increase a sandy soil's ability to retain added moisture, thereby reducing drought damage,
2. make the soil easier to cultivate,
3. improve drainage and aeration of clayey soils,
4. supply very small amounts of many essential elements needed for plant growth,

5. reduce adverse effects of excessive acidity and over fertilization by increasing the buffering capacity of the soil,
6. increase the biological activity of earthworms and other soil organisms, and
7. allow the soil to hold more plant nutrients for longer periods of time.

### Mulch

Compost can also be used to replace materials such as cypress mulch and straw as a mulching material. It may be applied in a 2 to 3 inch layer on top of the soil around trees, shrubs, flowers, and garden plants. Organic mulches are valuable because they:

1. reduce rainfall runoff, thereby increasing the water available to plants,
2. decrease water evaporation loss from soil,
3. help prevent soil erosion loss by wind or water,
4. help control weeds,
5. keep the soil cooler in hot weather and warmer in cold weather, and
6. present a pleasing appearance.

### Potting Mix

Compost may also be blended with soil, perlite, sand and other materials to make a potting mix for containerized plants.